

Driving Value to Your Process

Seital Direct Drive Centrifuges

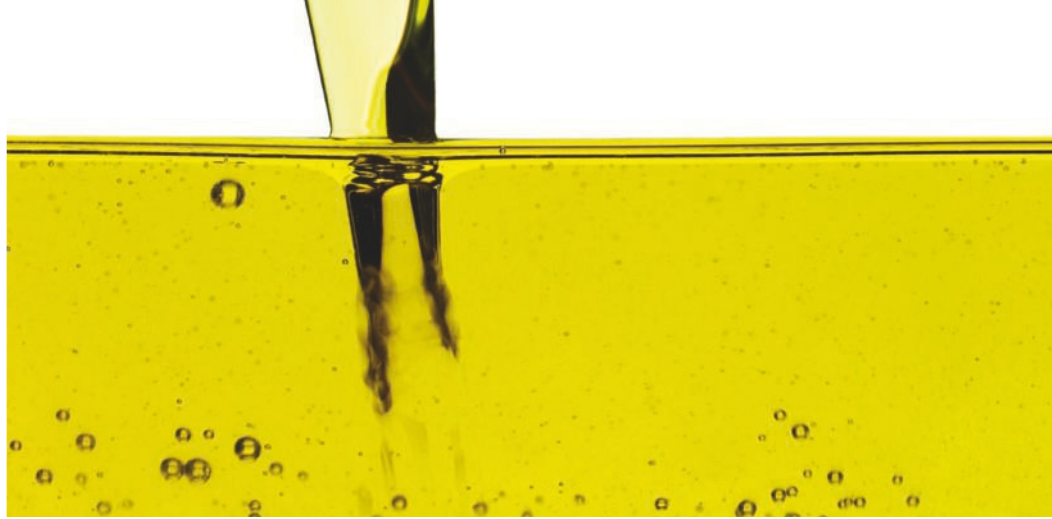

SPX® FLOW Seital, a trusted, global supplier of high-performance separators, offers processors new ways to reduce energy and lifecycle costs. It offers direct-drive centrifuges on its most popular separators. In addition to requiring less energy, this makes for more space-efficient, quieter and easier-to-maintain units.



Why Go Direct Drive with Seital Separators?

Direct Advantage

Direct drives are the most advanced way to translate energy from a rotating motor shaft to a centrifuge. They occupy less space and run quieter, enabling more elegant, streamlined operations. In highly competitive markets, where subtle production nuances and the visual appeal of the line itself can have significant impact on market value, running with state-of-the-art equipment can give you a distinct advantage.

Energy Matters

Transmitting power directly rather than with gears or belts reduces energy consumption. This can reduce operating costs significantly while also contributing to environmental sustainability. And the longer your process runs, the more your savings will add up.

Maintaining your Edge

Eliminating the need to change belts removes a significant maintenance task. And because there are fewer moving parts, direct drive centrifuges are easier to assemble and disassemble. This makes them easier to tune and repair, maximizing uptime and reducing overall cost of ownership.



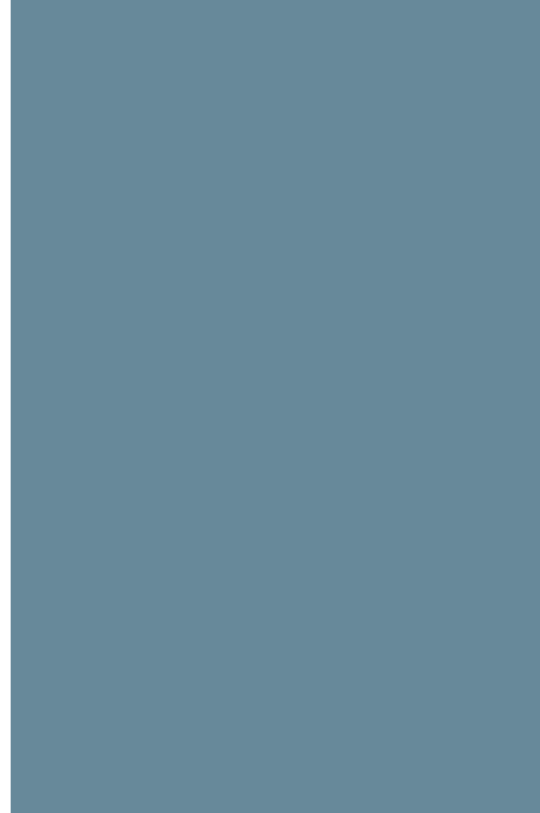



How does it work?

In traditional separator designs a gear or belt is used to transfer energy from the motor to the shaft and while these methods are well established they are not the most energy efficient design.

The direct-drive system has a specially developed motor mounted directly on the centrifuge shaft. This minimizes energy loss, enables a more compact footprint and, because there are fewer moving parts, reduces the maintenance.

Direct Drive – delivering value to your process

- **Reduced operation costs** – save energy costs
 - **Reduced maintenance** – simplified efficient design
 - **Smaller footprint** – less space needed for belt or gear assemblies
 - **Quieter operation** – fewer moving parts
 - **Intelligent performance** – inbuilt monitoring
 - **Fine European craftsmanship** – expert attention to every detail
- = Lower total cost of ownership**

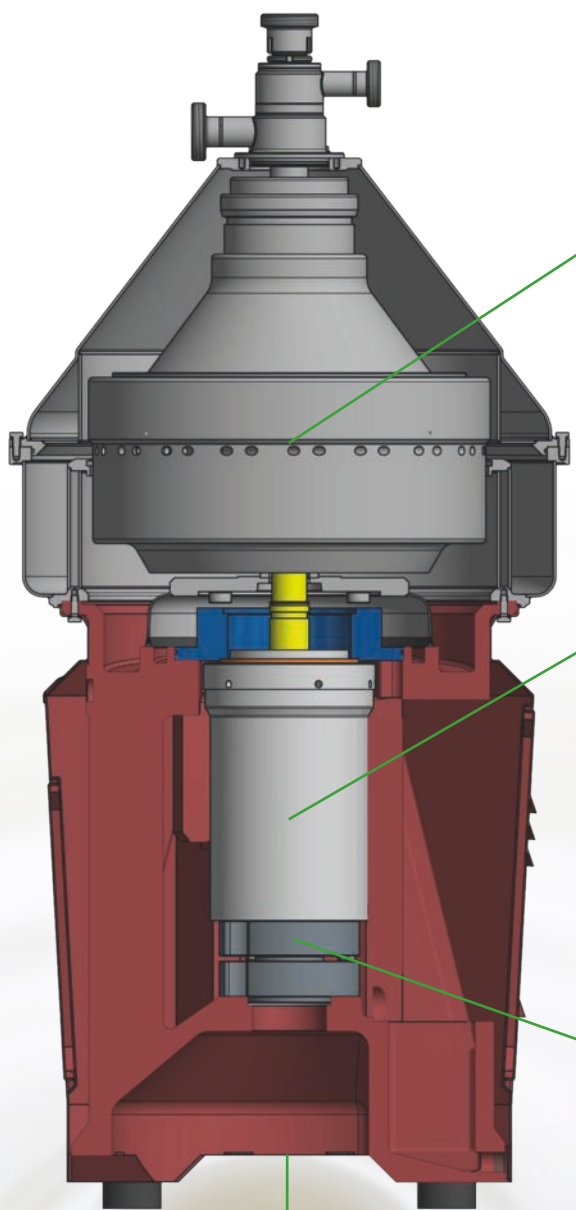

Standard centrifuge bowl and product zone

- Proven performance

Integrated motor mounted directly on the shaft

- Reduced maintenance

Easy maintenance on the motor cartridge assembly

- Plug & play

Compact footprint

- Reduced space





Why choose SPX FLOW's Seital Separators

- **Short installation time** – mounted on a compact pre-assembled skid – no need for a concrete foundation, electrical or hydraulic work
- **High performance** – innovative design developed using advanced software modeling tools enabling precise mechanical and hydraulic analysis
- **High uptime** – real-time operational diagnostics possible via remote monitoring allowing functionality check by technical office
- **Advanced process control** – customization of user-friendly and automatic regulation processes
- **Lower investment requirement** – wide range of models and options enable customization to customer needs
- **Deep applications knowledge** – more than 35 years of separation experience
- **Peace of mind** – global aftersales support network
- **Fine craftsmanship** – expert attention to every detail



Global Presence and Expertise

Through its Seital brand, founded in Santorso Italy in 1983, SPX® FLOW offers decades of experience and technology based on in-depth understanding of applications, flow dynamics and centrifuge technology. SPX® FLOW's Seital vertical disk stack centrifuges provide high quality separation and clarification in compact solutions that offer excellent performance with a low total cost of ownership.

Its technology delivers results of exceptional quality with high efficiency and assured hygienic performance for a wide range of applications including:

- Beers
- Wines
- Teas
- Oil refining
- Milk skimming
- Whey processing
- Bacteria clarification

Your next separator

So, if you are expanding or replacing your separators, be sure to contact SPX® FLOW about a Seital model with a direct drive configuration. You'll get the extensive applications knowledge and high product quality for which Seital separators are known the world over, plus you'll enjoy greater energy efficiency, more space efficiency and lower cost of ownership.

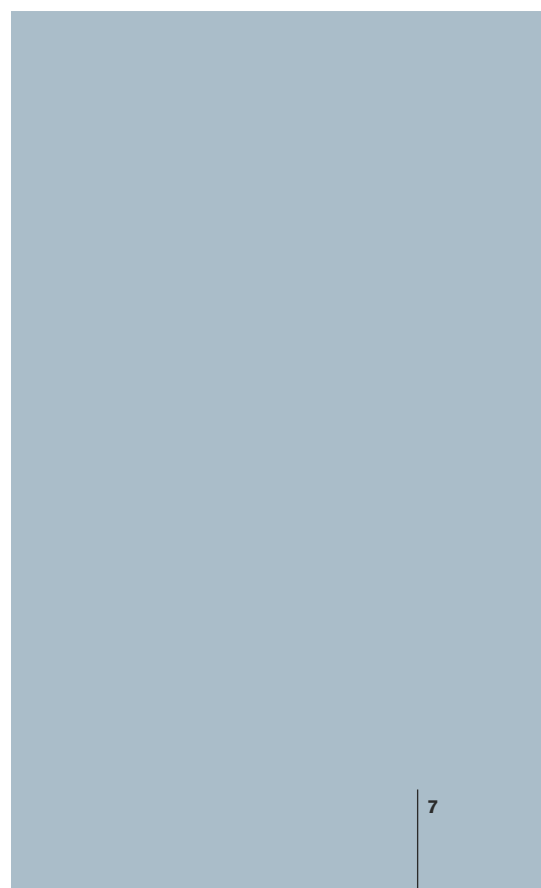
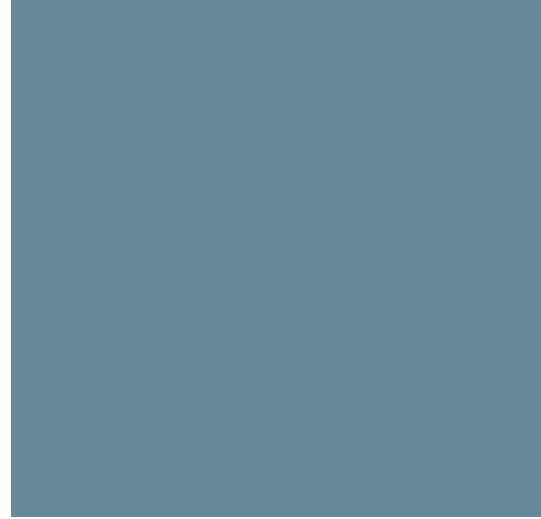

Driving Value
to Your Process

SEITAL DIRECT DRIVE
CENTRIFUGES

SPXFLOW

Global locations

SPX FLOW, Inc.

611 Sugar Creek Road
Delavan, WI 53115
United States of America
P: 1 800-252-5200
E: leads@spxflowleads.com

SPX FLOW, Inc. - Italy

Via delle Prese, 14
36014 Santorso (VI)
Italy
P: 39 0445 540232
E: leads@spxflowleads.com

SPX FLOW, Inc. - China

No. 666 Fengjin Road
Xidu Industrial Park - Shanghai
201401 China
P: +86 21 6715 8181
E: leads@spxflowleads.com

SPX FLOW reserves the right to incorporate our latest design and material changes without notice or obligation.

Design features, materials of construction and dimensional data, as described in this bulletin, are provided for your information only and should not be relied upon unless confirmed in writing. Please contact your local sales representative for product availability in your region. For more information visit www.spxflow.com.

The green ">", Anhydro, APV, Waukesha Cherry-Burrell, and Seital Separation are registered trademarks of SPX FLOW, Inc.

SS-114-GB VERSION 01/2020 ISSUED 12/2020

COPYRIGHT © 2020 SPX FLOW, Inc.